

PFAFF®

Creative 2.0

Parts list

New feed system

From product Nr 850115-xx

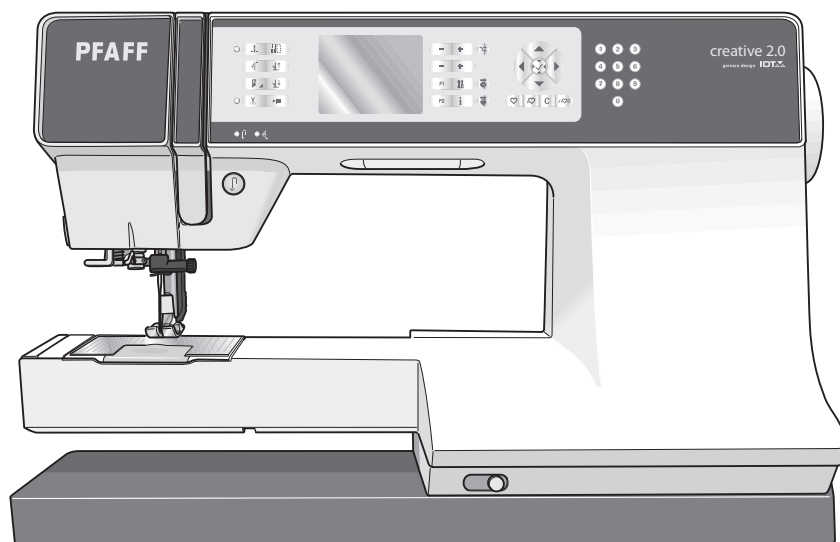

Nicht nummerierte Teile im Katalog werden nicht geliefert.

The parts mentioned without number in the parts list are not available.

Les pièces qui ne sont pas numérotées dans la liste de pièces détachées ne peuvent être livrées.

Bei Bestellung von Ersatzteilen muss die Modell-Nr. der Maschine, die Seitenzahl des Kataloges und die Teilenummer angegeben werden.

Prière d'indiquer dans vos commandes de pièces de rechange, le numéro de la machine, le numéro de la page dans la liste des pièces détachées, ainsi que les numéros des pièces commandées.

When ordering spare parts, please state the model number, the page number in the catalogue of spare parts and the number of the parts called for.



Please note that on disposal, this product must be safely recycled in accordance with relevant National legislation relating to electrical/electronic products. If in doubt please contact your retailer for guidance.



Bitte beachten Sie, dass hinsichtlich der Entsorgung dieses Produkts, vorschriftsmäßig entsprechend der gültigen nationalen Gesetzgebung für elektrische/elektronische Produkte, recycelt werden muss. Bei Zweifel setzen Sie sich bitte mit Ihrem Fachhändler in Verbindung.



Veuillez noter qu'en cas de destruction, ce produit doit bénéficier d'un recyclage sécurisé, conforme à la législation nationale applicable aux produits électriques/électroniques. En cas de doute, veuillez contacter votre distributeur agréé.

- All casted parts within our products are marked with name of material if allowed by size.
- All molded plastic parts within our products are marked with name of material if allowed by size.

STANDARD ACCESSORIES

413021619	ACCESSORY BAG CPL.
413190401	BRUSH
412381501	SCREWDRIVER
401539901	BUTTON HOLE KNIFE
413105601	CLEARANCE PLATE
820921096	BOBBIN 10 PACK
820774096	PRESSER FOOT 1A FANCY STITCHFOOT W IDT
820256096	PRESSER FOOT 3 BLINDHEM FOOT W IDT
820248096	PRESSER FOOT 4 ZIPPER FOOT
820672096	PRESSER FOOT 5M MAN. BUTTUNHOLE FOOT
820671096	PRESSER FOOT 6A EMB/SENSORMATIC FREE MOTION FOOT
820 249 096	PRESSER FOOT 7 ROLLED HEM FOOT W IDT
412610701	FELT PAD
620098796	NEEDLE BOX, INSPIRA
412570101	SLEEVE, LAMP
412397701	THREAD NET 15X100
413051602	SPOOL HOLDER 35MM
413051603	SPOOL HOLDER 45MM
820 251 096	EDGE RULER

A

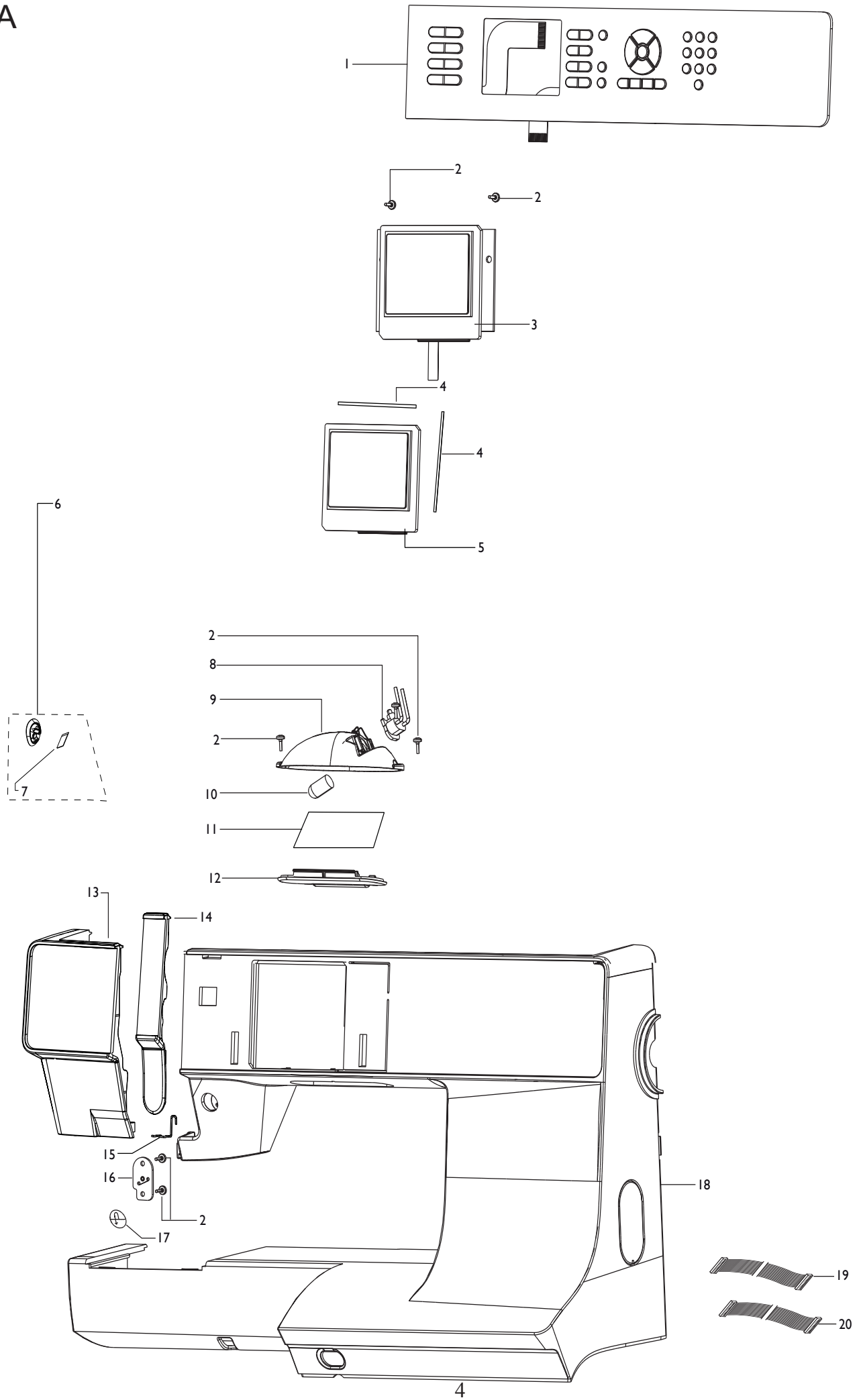

1	413169701	KEYBOARD
2	411966801	SCREW PT 30*7,5 FZB TORX
3	413168401	PCB ASSEMBLY, LCD
4	412520103	SEALING
5	413122001	DISPLAY GLASS
6	413066201	THREAD KNIFE CPL.
7	412423701	THREAD CUTTER
8	412196001	LAMP HOLDER
9	413162101	REFLECTOR
10	413181803	LAMP, 24V, 3W
11		COOLING TAPE, LED ARM
12	413117601	LAMP COVER
13	413136603	COVER SEWING HEAD CPL.
14	413136403	GUIDE CPL.
15	413068801	THREAD GUIDE
16	413067401	BOARD, REVERSE BUTTON
17	413057601	REVERSE BUTTON
18	413117101	FRONT COVER
19	412546918	CABLE ASSEMBLY (18P)
20	412546917	CABLE ASSEMBLY (20P)

B

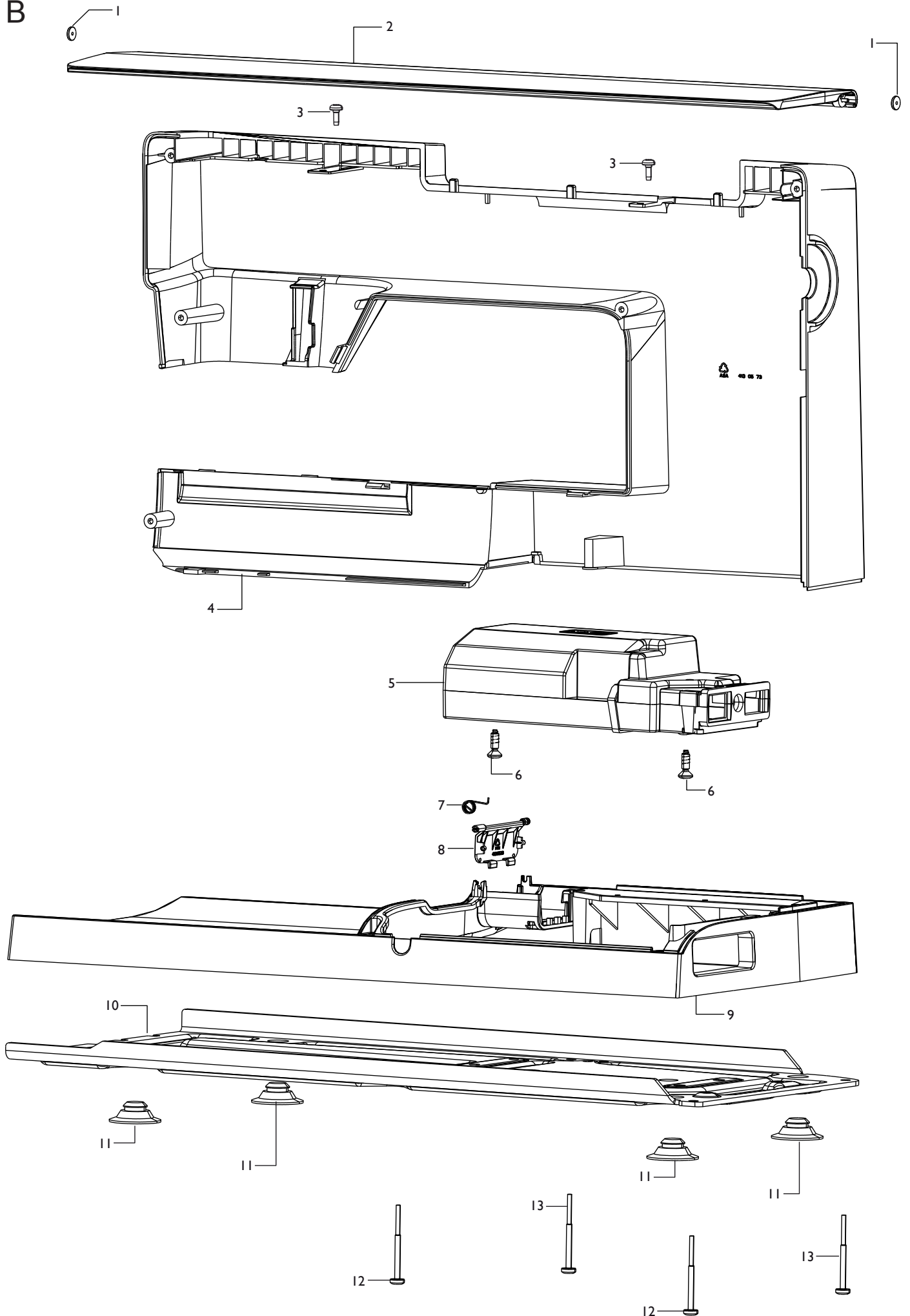

1	413139901	BUSHING
2	413053306	LID CPL.
3	412056005	SCREW TAPTITE M4*10 TORX
4	413057301	BACK COVER, PFAFF HIGH
5	413390102	POWER SUPPLY CPL.
6	411967107	SCREW PT FS 40*35 FZB TORX
7	413068601	TORSION SPRING
8	413052501	LID, XY-UNIT
9		BOTTOM COVER CPL. NO KNEE LIFT
10	412954501	BOTTOM PLATE
11	412305001	RUBBER FOOT, BASE PLATE
12	411966812	SCREW PT 40*40 FZB TORX
13	411966813	SCREW PT 40*50 FZB

C

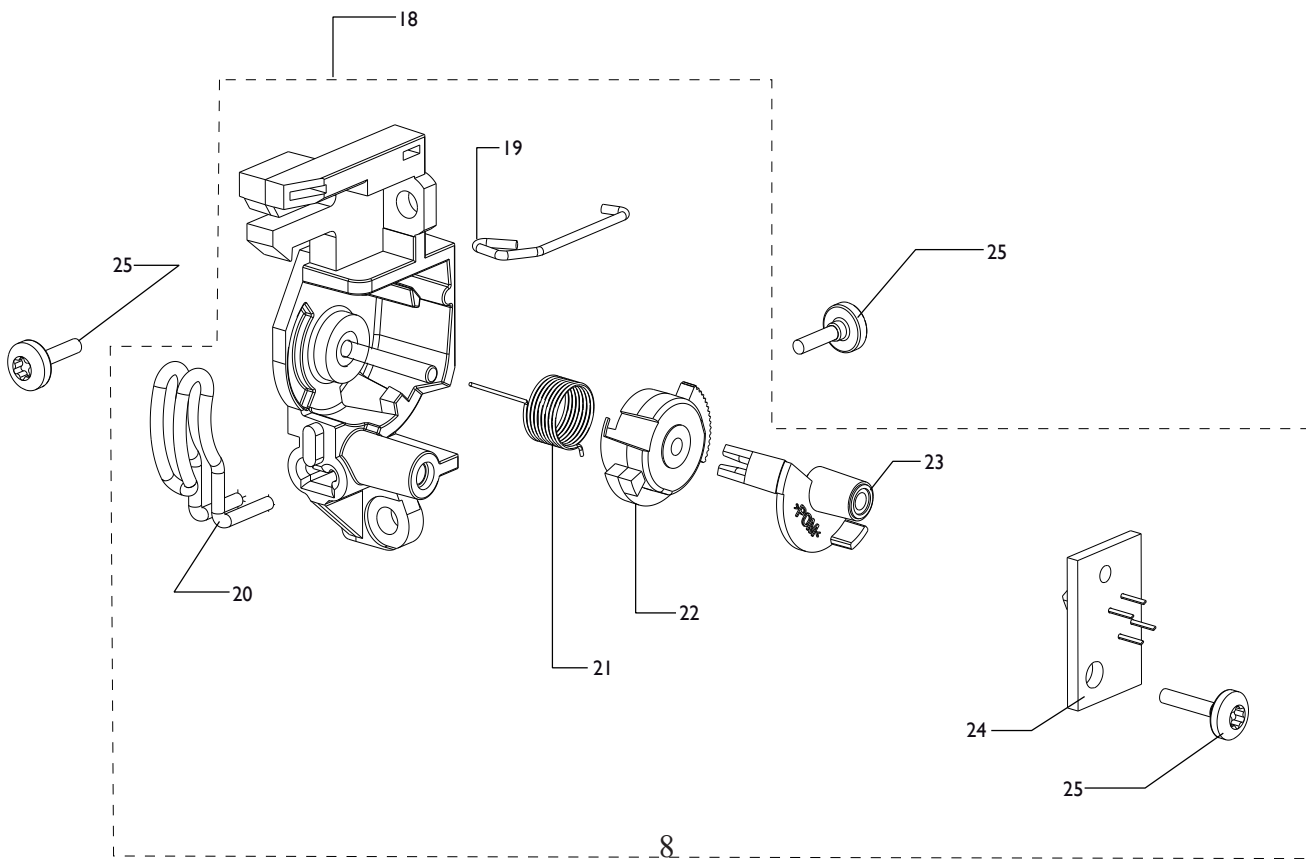
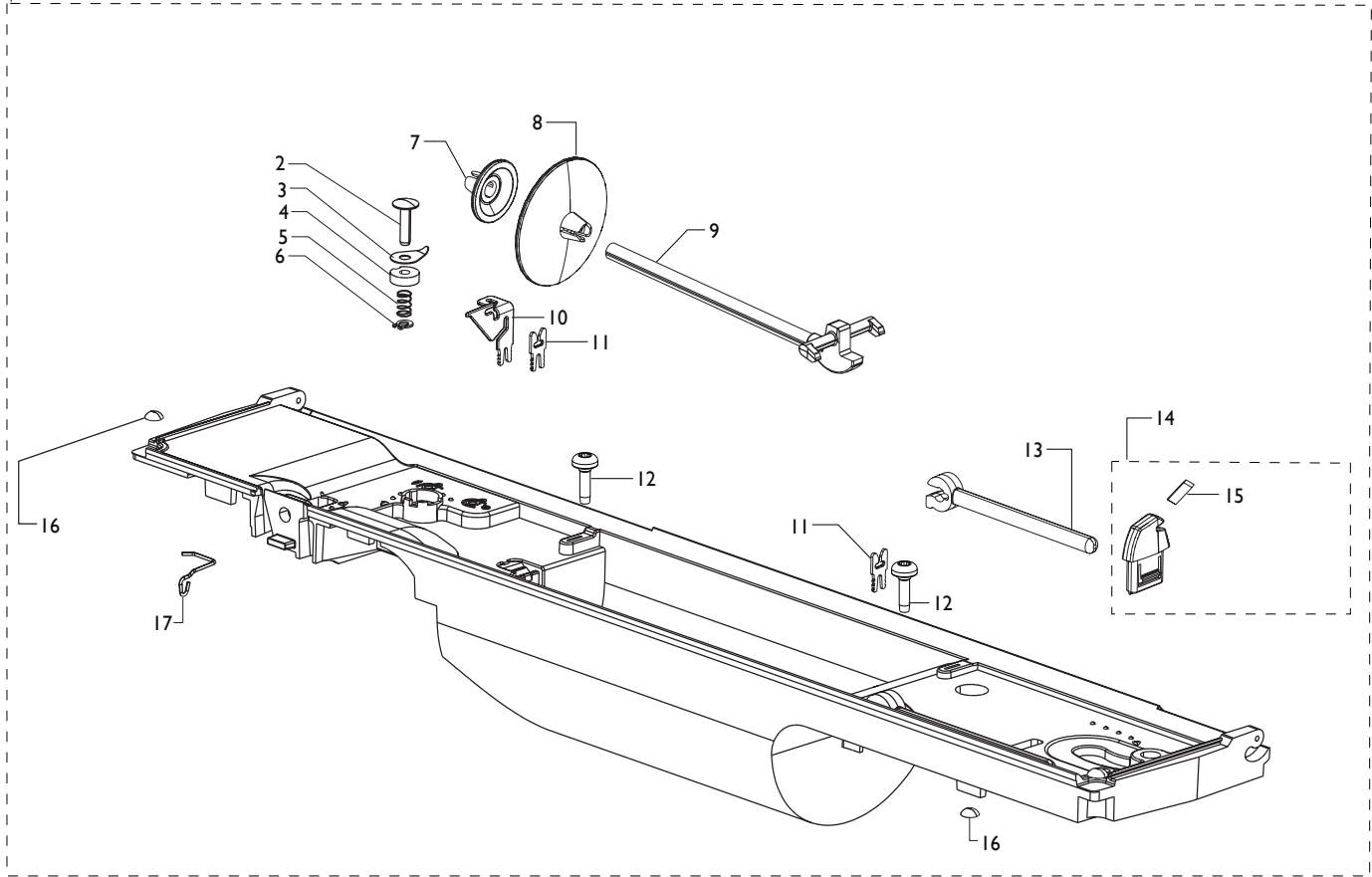

1	413064706	TOP COVER CPL.
2	9303017435000	GUIDE PIN
3	9303906805000	THREAD GUIDE, BOBBIN WINDER
4	9303205025000	THREAD GUIDE
5	9304006005000	SPRING
6	1261814045000	RING PN 12618-3,5
7	413051601	SPOOL HOLDER 22 MM
8	413051603	SPOOL HOLDER 45 MM
9	413064501	REEL PIN
10	413190001	THREAD GUIDE CPL.
11	413060201	THREAD GUIDE
12	412056005	SCREW TAPTITE M4*10 TORX
13	412960401	THREAD REEL PIN
14	413022501	COVER THREAD KNIFE CPL. WIN.
15	412423701	THREAD CUTTER
16	412569701	DAMPER
17	413064602	THREAD GUIDE
18	413004005	THREAD SENSOR CPL.
19	413004501	THREAD CONTROL, THREAD SENSOR
20	412519301	THREAD GUIDE
21	412519202	CHECK SPRING
22	413004301	ADJUSTING SLEEVE
23	413004402	SENSOR THREAD TENSION
24	413017602	THREAD SENSOR ASSEMBLY
25	411966820	SCREW 30*10 FZB KOMBITORX

D

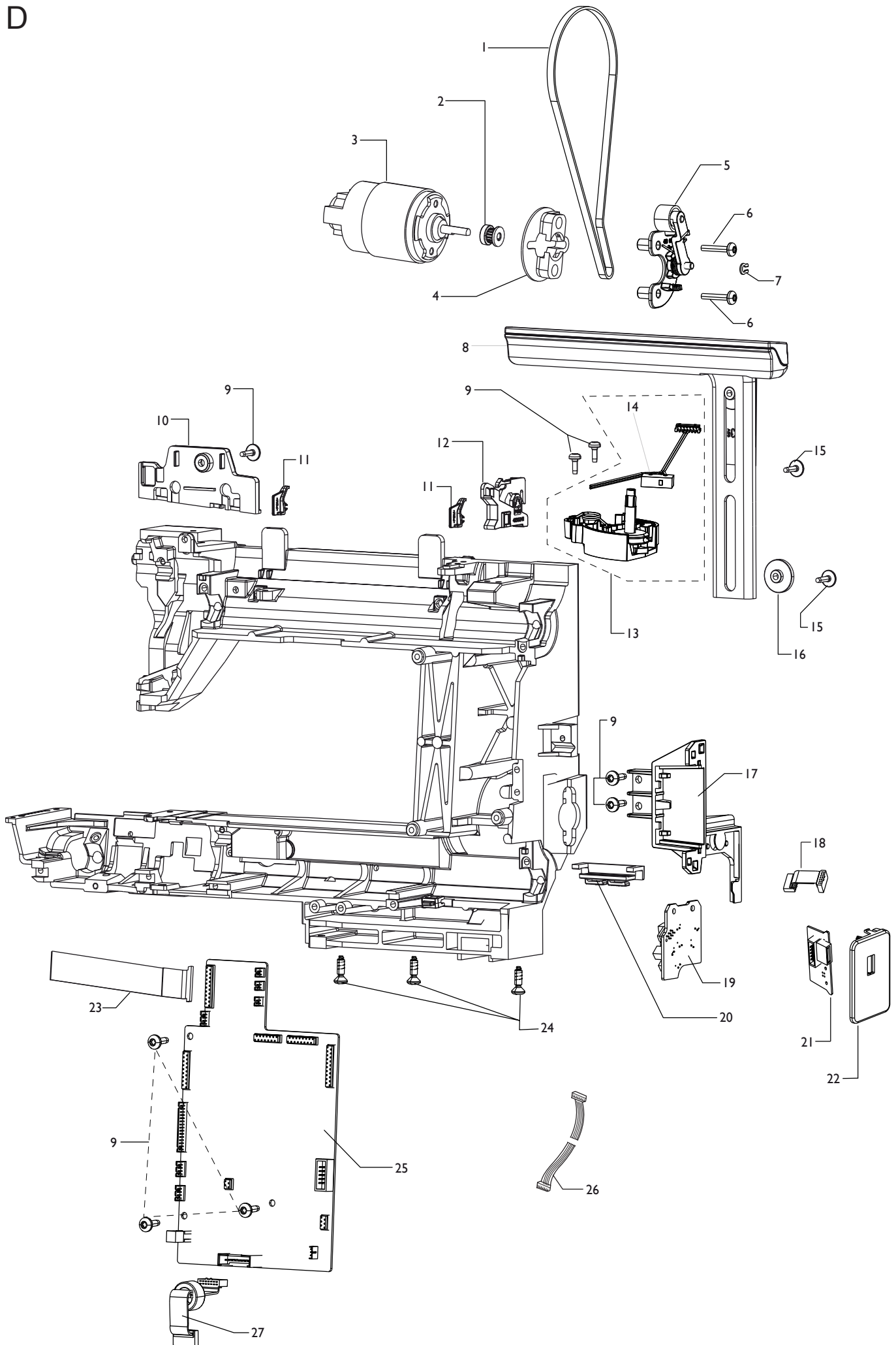

1	413020201	COG BELT MOTOR
2	412353302	DRIVING WHEEL MOTOR 350, 400, 500
3	9233011191000	ENGINE DOMEL
4	412999902	RUBBER DAMPER, MOTOR
5	412971902	BELT STRETCHER CPL.
6	412211415	SCREW M4*20 TORX
7	735613640	COMPRESSION RINGS Ø4
8	413056101	HANDLE PART CPL.
9	412056006	SCREW TAPTITE M4*12 TORX
10	413063901	CABLE SHIELD
11	413024201	CABLE CLAMP
12	413024101	CABLE LOCATOR
13	412955501	BOBBIN WINDING UNIT
14	413049101	MICRO SWITCH CPL.
15	413169401	SCREW FLANGE M4*14 TT TORX
16	413056501	BUSHING, HANDLE
17	412985502	HOLDER
18	413108801	CABLE, USB
19	412986401	SENSOR BOARD, ASS
20	413075601	CABLE LOCATOR
21	413024402	USB BOARD SINGLE CPL.
22		COVER, USB SINGEL
23	412546912	CABLE ASSEMBLY (18P)
24	412056001	SCREW TAPTITE M5*14 TORX
25	413159345	CONTROL BOARD
26	412546913	CABLE ASSEMBLY (6P)
27	412349703	CABLE TRANSF.-CONTROL BOARD

E

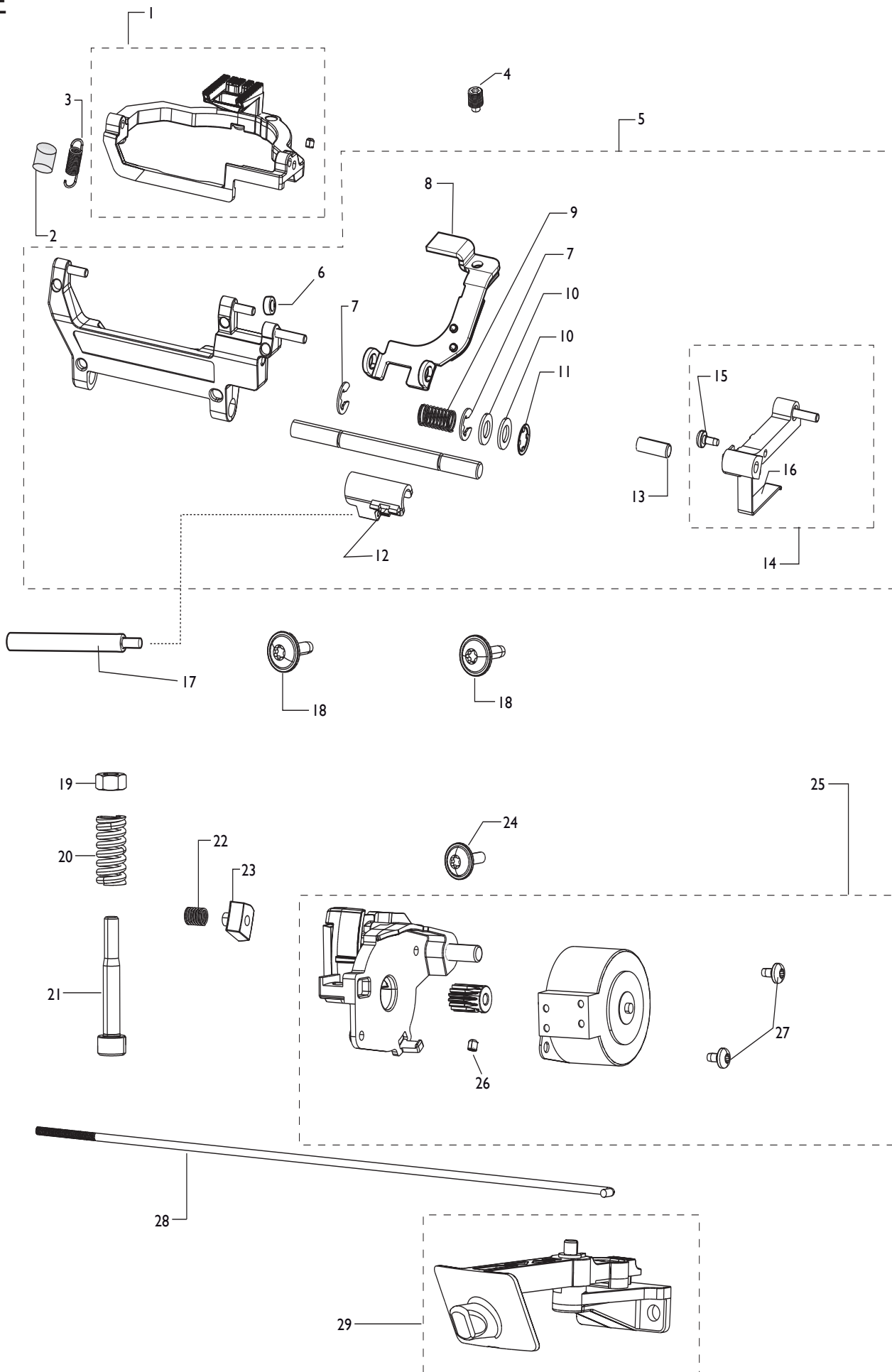

1	413201304	FEED DOG CPL.
2	413112601	BUFFER
3	413006802	TENSION SPRING, FRAME FEED DOG
4	413201201	ADJUSTMENT SCREW, FEEDER
5	413269008	CARRIAGE FEED CPL.
6	413007801	SPACER, FEED
7	735310920	SNAP RING E-5
8	413200901	LEVER FEED LIFT CPL.
9	412962501	SPRING, FEED DOG LOWERING
10	412829103	WASHER, FEED UNIT
11	412368001	LOCK WASHER
12	413034201	INSERT, LEVER FEED LIFT
13	412316023	INA PIN NRB 4*19,8 0-2UM
14	412961601	LINK, CARRIAGE FEED CPL.
15	412056004	SCREW TAPTITE M3*6 TORX
16	412961501	SPRING, FEED
17		PUSH ROD FEED DROP
18	413169401	COLLAR SCREW TT TORX 4*14
19	413025401	NUT M5*0,5
20	412963601	SPRING
21	412963701	SCREW BALANCE ADJUSTMENT
22	412961701	SPRING, SLIDING BLOCK
23	412961801	BLOCK, GUIDE
24	413034402	COLLAR SCREW M4*10, LEFT HAND
25	412963501	STEPPING MOTOR UNIT, FEED
26	411968703	SET SCREW FLAT, M3*3 TORX
27	412056011	SCREW TAPTITE M3*5 TORX
28	413034101	PULL WIRE, FEED DOG DROP
29	413142201	MECHANISM, FEED DOG DROP CPL.

F

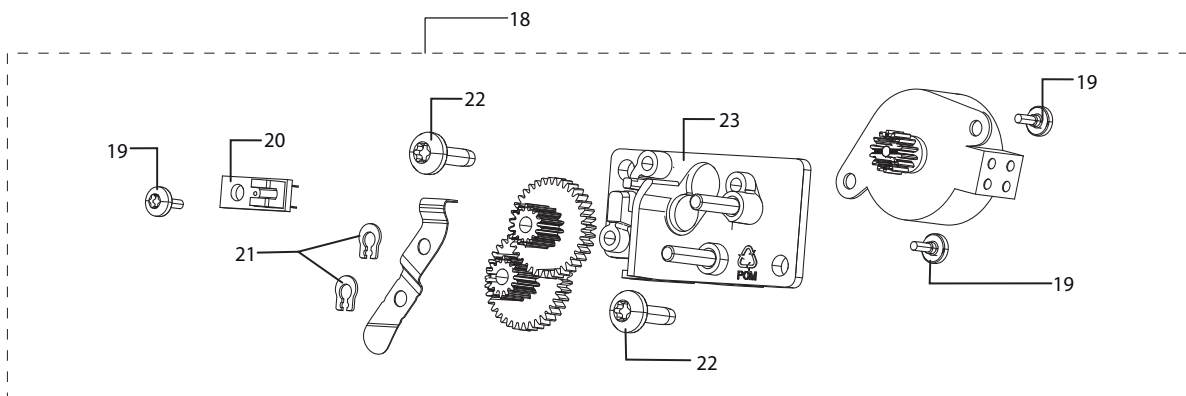
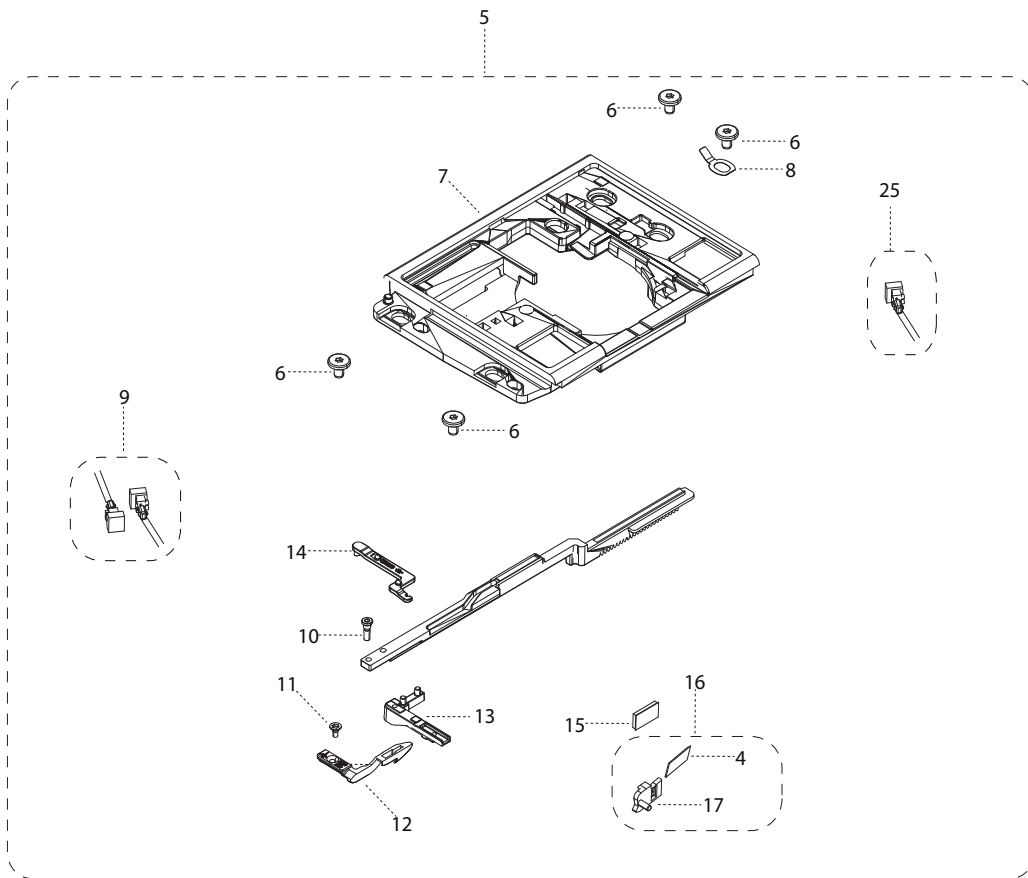
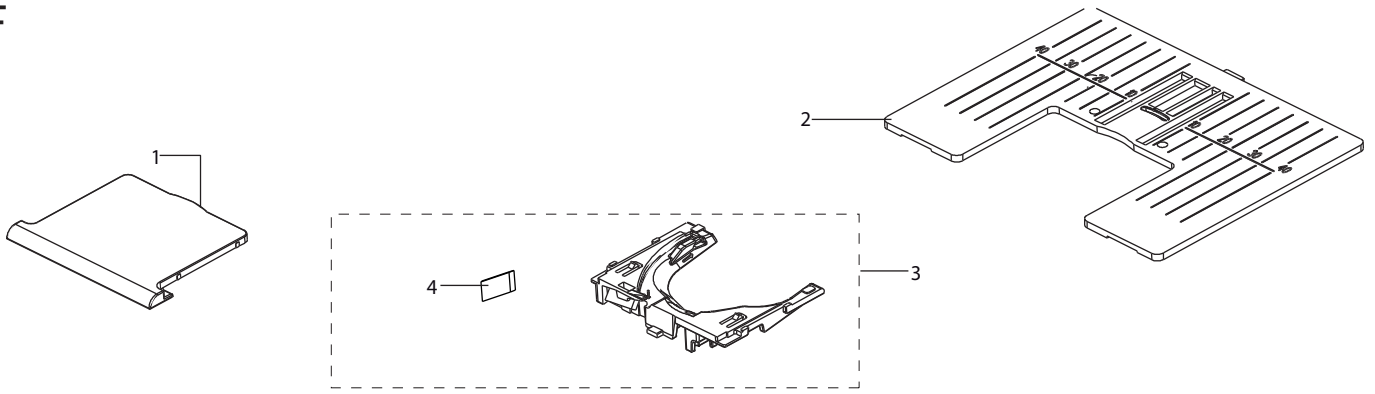

1	412963901	BOBBIN COVER
2	412964308	STITCH PLATE PFAFF INCH/MM
3	413025601	RETAINER
4	412423701	THREAD CUTTER
5	412964002	HOOK COVER CPL. CUT. AND SENS.
6	412287903	SCREW M4*5 FZB
7	412964105	HOOK COVER
8	412997701	ESD SPRING, STITCH PLATE
9	413101502	DOUBLE COATED TAPE
10	413010001	GUIDE PIN
11	412280501	SCREW, COUNTERSUNK
12	413007101	FETCHER
13	413072201	CONNECTING PART, FETCHER
14	413007301	FETCHER UPPER THREAD
15	413116701	THREAD BRAKE
16	413047301	KNIFE HOLDER CPL.
17	413007701	KNIFE HOLDER
18	413007402	STEPPING MOTOR CPL.
19	411966828	SCREW PT 30*6 FZB TORX
20	413072501	CUT SENSOR ASS.
21	735612440	COMPRESSION RINGS Ø3
22	412056006	SCREW TAPTITE M4*12 TORX
23	413353001	MOTOR PLATE CPL.

G

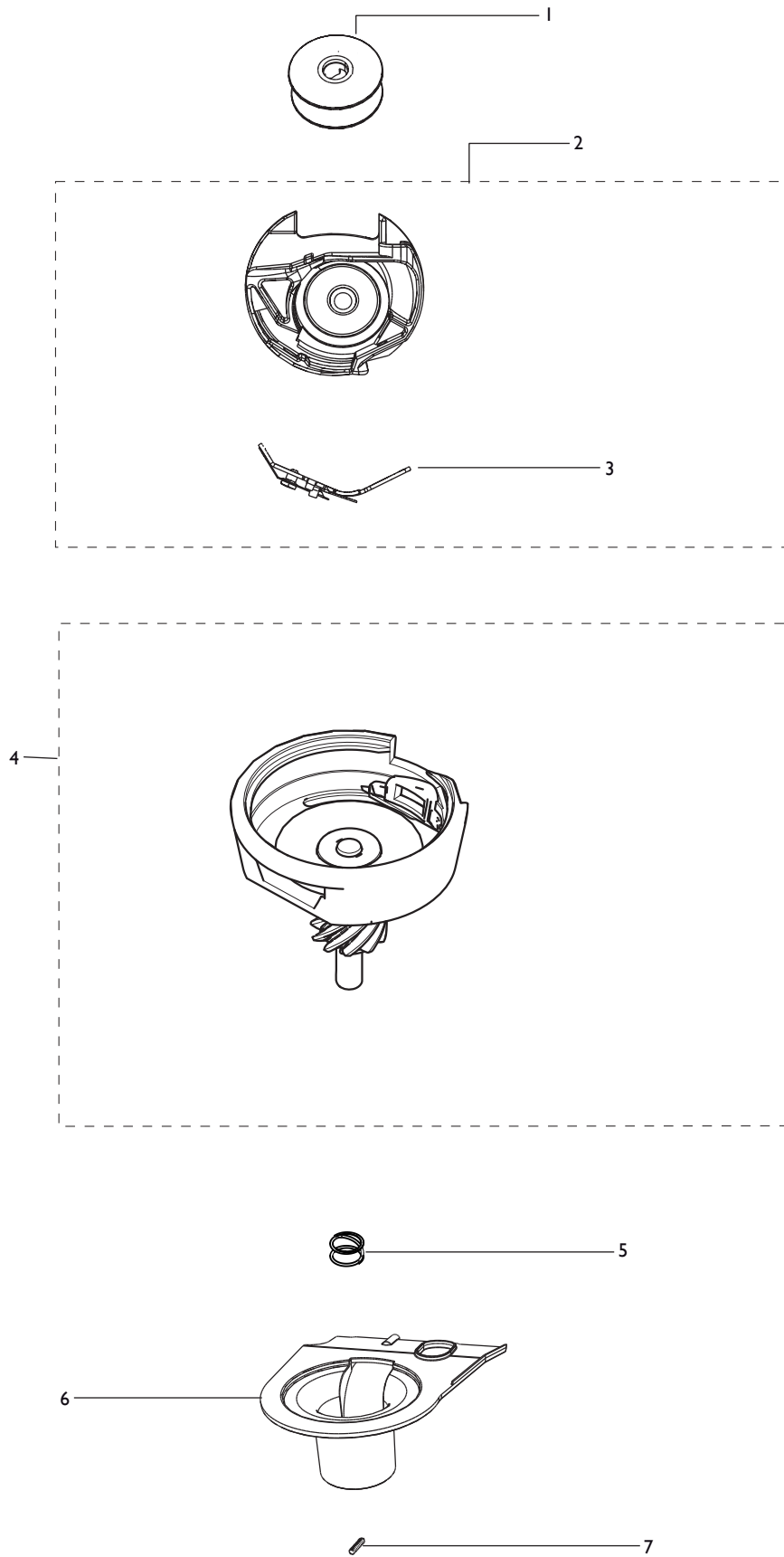

1	820921096	BOBBINS CPL. PF, GREY 10P
2	413058903	BOBBIN CASE CPL.
3	412471601	THREAD TENSION CPL.
4	412876902	HOOK CPL WITH SHAFT
5	412930101	SPRING, HOOK
6	412964502	DUST COVER
7	728528705	SCREW M4*8

H

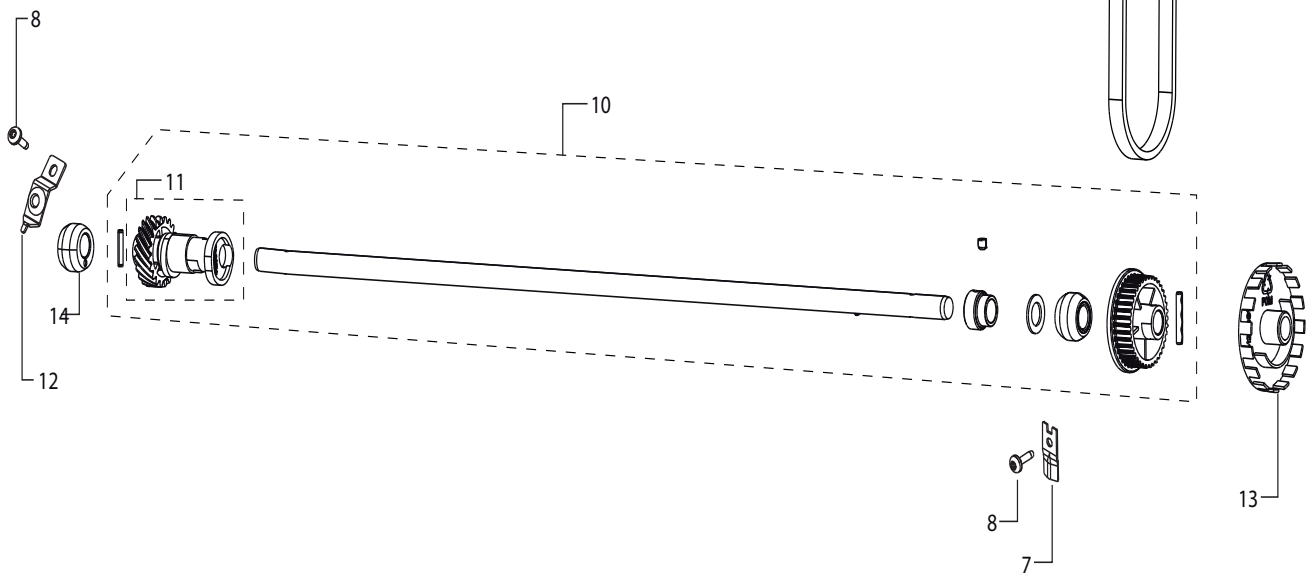
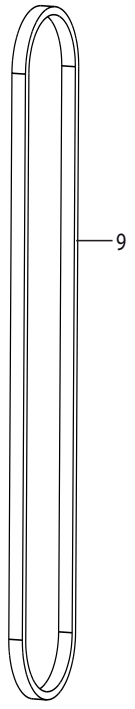
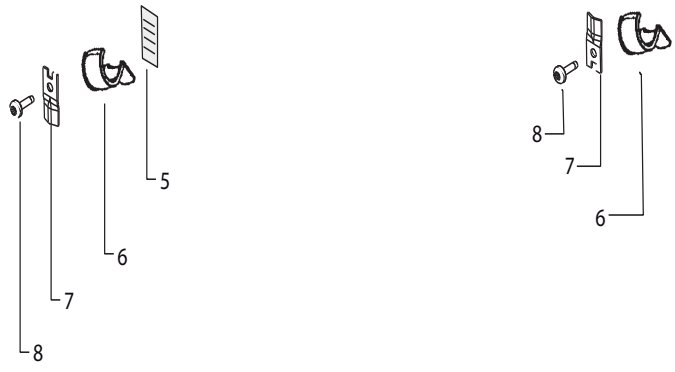
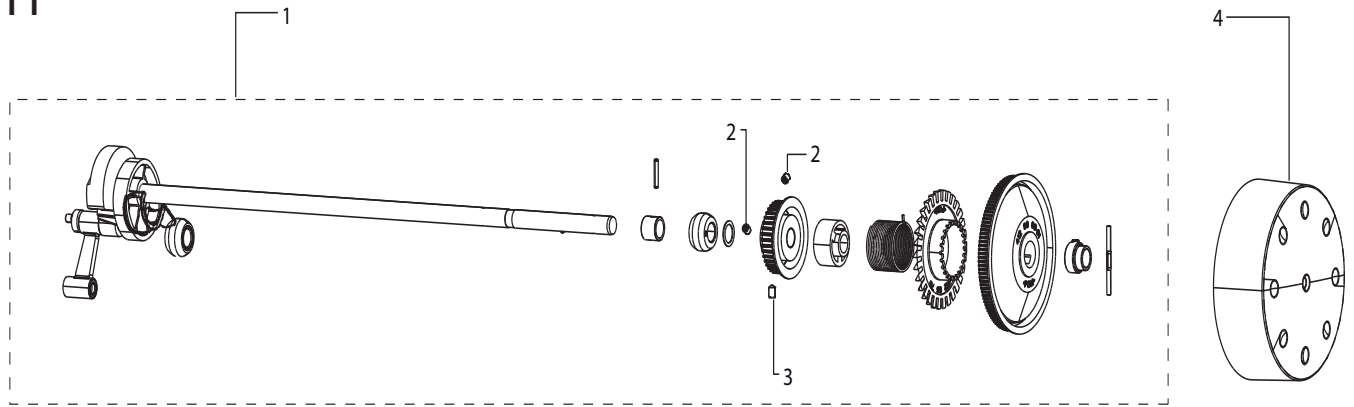

1	412966705	UPPER SHAFT CPL.
2	411968706	SET SCREW FLAT, M4*4 TORX
3	411968807	SET SCREW POINTED, M4*6 TORX
4	413040301	HAND WHEEL
5	412687601	GROUND TAPE
6	412558401	ABSORBER
7	412328401	CLAMP
8	412056006	SCREW TAPTITE M4*12 TORX
9	413020301	COG BELT UPPER-LOWER SHAFT
10	412967905	LOWER SHAFT CPL.
11	412964402	ECCENTRIC FEED CPL.
	412964403	ECCENTRIC FEED CPL. (BOX) From product nr 850 144 xxx
12	412318101	CLAMP LOWER SHAFT
13	412968101	SHIELD, REVOLUTION INDICATOR
14	412491601	BEARING ECC.

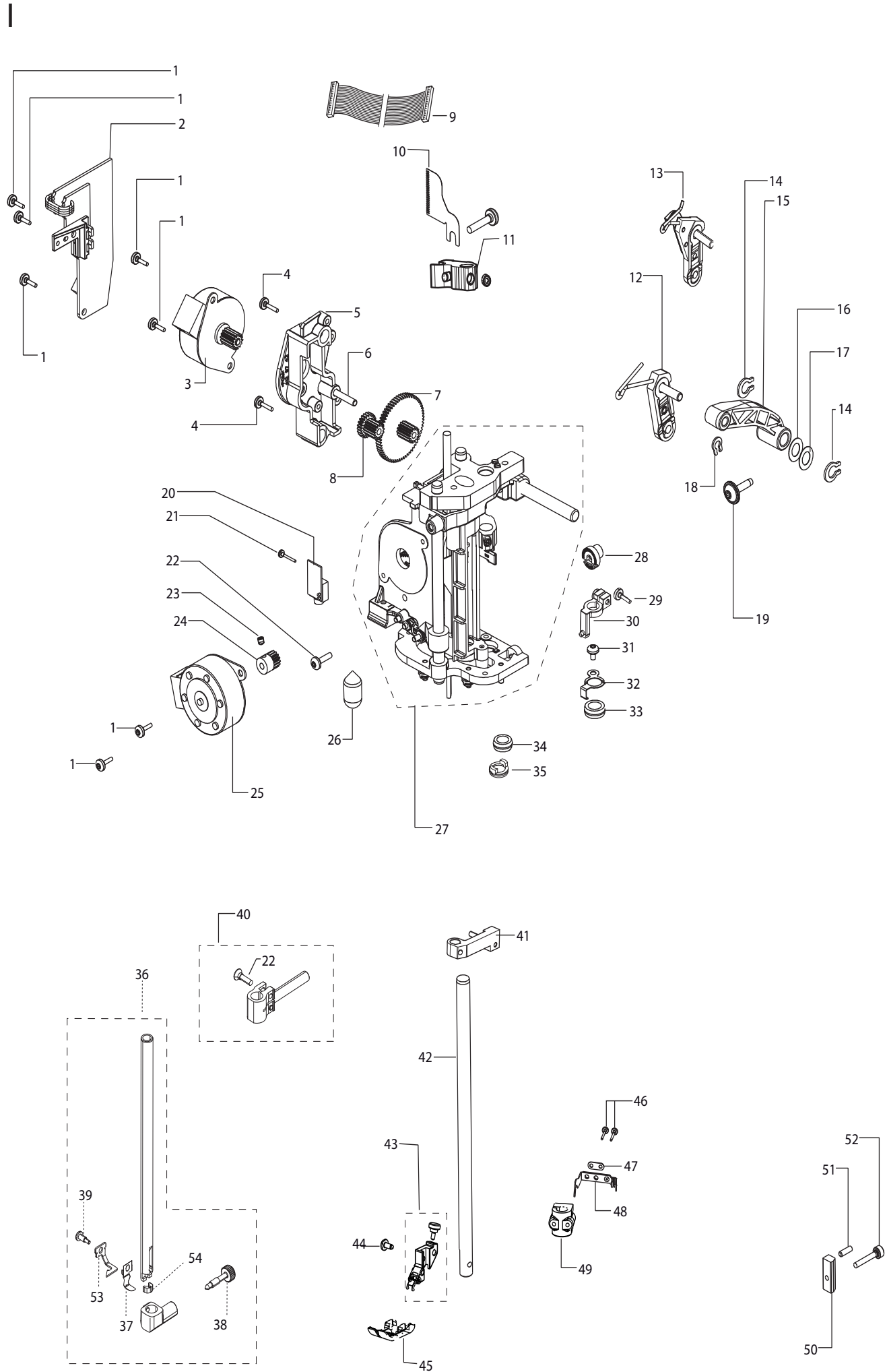

1	411966801	SCREW PT 30*7,5 FZB TORX
2	413067003	CONN.BOARD SERVO SENS.
3	413005901	STEPPING MOTOR CPL.
4	411966820	SCREW 30*10 FZB KOMBITORX
5	412974201	GEAR HOUSE, SERVO
6	412316010	INA PIN NRB 3*17,8 0-3UM
7	412974401	GEAR WHEEL, SERVO SEC
8	412974301	GEAR WHEEL SERVO PRIM.
9	412546912	CABLE ASSEMBLY (18P)
10	412973901	SHIELD, PRESSER FOOT SERVO
11		GUIDE, SERVO CPL.
12	412394401	210,230, 250, VER1
13	413300302	TAKE UP LEVER CPL. WITH LINK, VER2
14	735615340	COMPRESSION RINGS Ø6
15	413047401	LINK
16	411980601	WASHER
17	412001301	SPRING WASHER Ø6,1/9X0,1
18	735613640	COMPRESSION RINGS Ø4
19	413169401	COLLAR SCREW TT TORX 4*14
20	413031001	BUTTONSENS.CONN.ASS.
21	411966821	SCREW PT 18*10 FZB TORX
22	412211404	SCREW M3*10 TORX
23	411968703	SET SCREW FLAT, M3*3 TORX
24	413057201	GEAR, Z-Z
25	412993901	STEPPING MOTOR
26	413181802	LAMP, 24V, 5W
27	413244201	SEWING HEAD CPL.
28	412966501	CALIBRATION KNOB
29	413019001	SCREW K 30*8 PT WN 1452-S
30	412993502	STROKE LIMITER
31	412211401	SCREW M3*4 TORX
32	413060301	CLIPS, GABLE LOWER
33	412500601	BEARING
34	412501501	BEARING 10/6,35-4
35	412504701	LOCKING DEVICE
36	68003690	NEEDLE BAR CPL PF
37	413304201	THREAD LOCK, NEEDLE HOLDER
38	413372901	SCREW NEEDLE HOLDER PF
39	68002284	SCREW THREAD LEADER
40	412993603	CROSS HEAD CPL.
41	413045801	PRESSER BAR GUIDE SERVO, IDT
42	412285403	PRESSER BAR
43	413039201	HOLDER PRESSER FOOT CPL.
44	413040401	SCREW HOLDER PRESSER FOOT
45	820773096	STANDARD PRESSER FOOT W. IDT
46	411966825	SCREW PT 16*8 FZB TORX
47	412876701	WASHER, NEEDLE THREADER
48	413238402	NEEDLE THREADER
49	413053601	HOLDER, NEEDLE THREADER
50	412966601	WEDGE
51	728522205	SOCKET SET SCREW FLAT POINT
52	725522805	SCREW M3*16 INSEX
53	68008796	THREAD GUIDE
54	68016246	CLAMPING PIECE

J

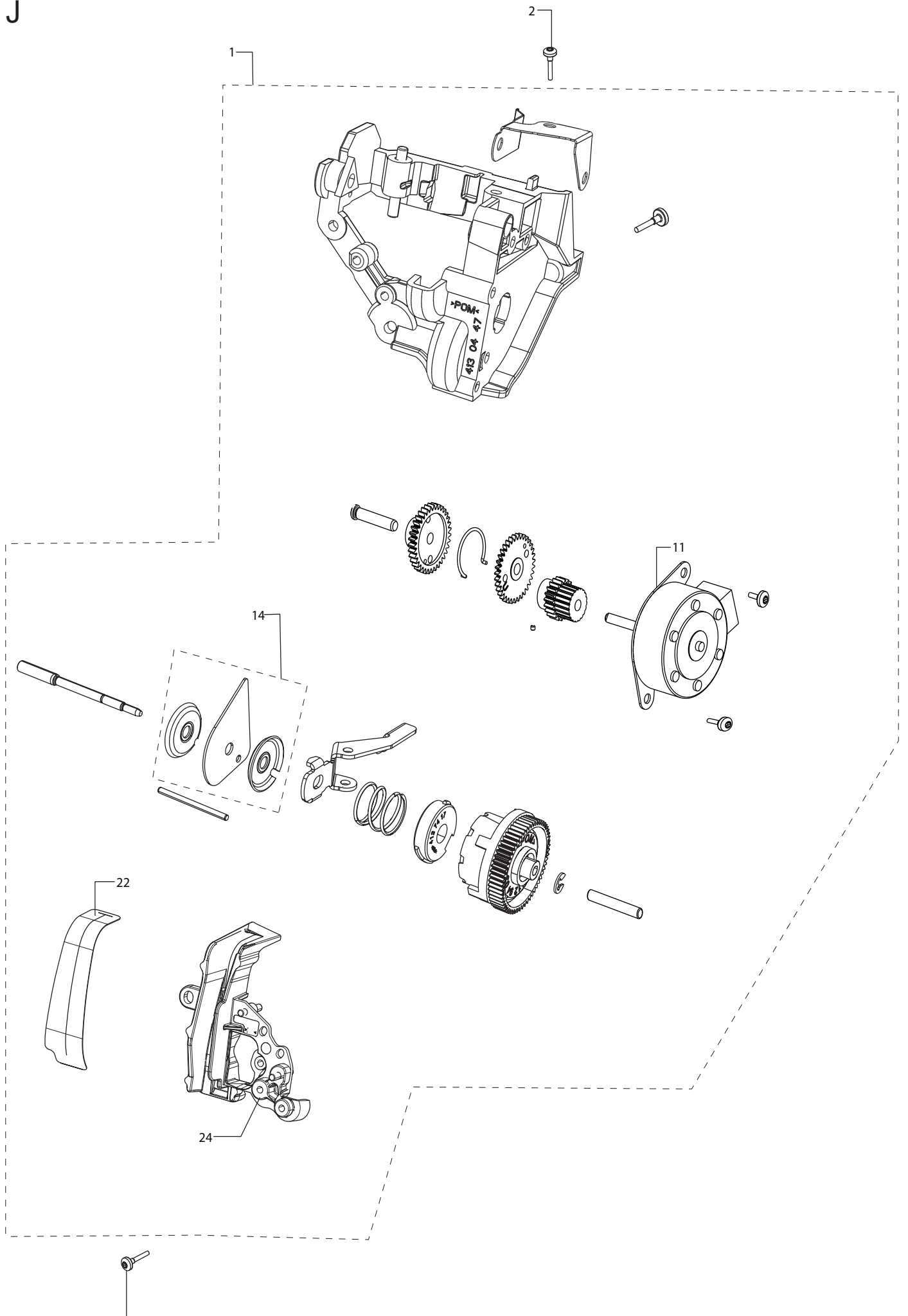

1	412940208	THREAD TENSION ASS.
2	411966803	SCREW PT 30*12 FZB TORX
3	412940603	CONTACT SPRING THREAD TENSION
4	412056006	SCREW PT 40*10 FZB TORX
5	413056003	SHAFT, THREAD TENSION
6	413059101	INTERMEDIATE GEAR, FIXED
7	412442801	SPRING GEAR WHEEL
8	413059202	INTERMEDIATE GEAR, MOVABLE
9	412742401	GEAR-FIXED
10	411968703	SET SCREW FLAT, M3*3 TORX
11	412993903	STEPPING MOTOR
12	411966828	SCREW PT 30*6 FZB TORX
13	412940101	SHAFT, THREAD TENSION
14	413106402	THREAD DISK KIT
15	413113201	PIN
16	412940501	RELEASE LEVER, THREAD TENSION
17	413159501	COMPRESSION SPRING, THREAD TENSION
18	412741701	NUT THREAD TENSION
19	412940404	SPRING HOUSE THREAD TENSION
20	735310620	LOCK WASHER 2.3
21	412316060	INA PIN NRB 3*23,8 0-2UM
22	413017901	PROTECTION THREAD TAKE UP, VER1
	413218501	SEALING, TAKE UP LEVER, VER2
23	411966820	SCREW 30*10 FZB KOMBITORX
24		PRINT, GUIDE

K

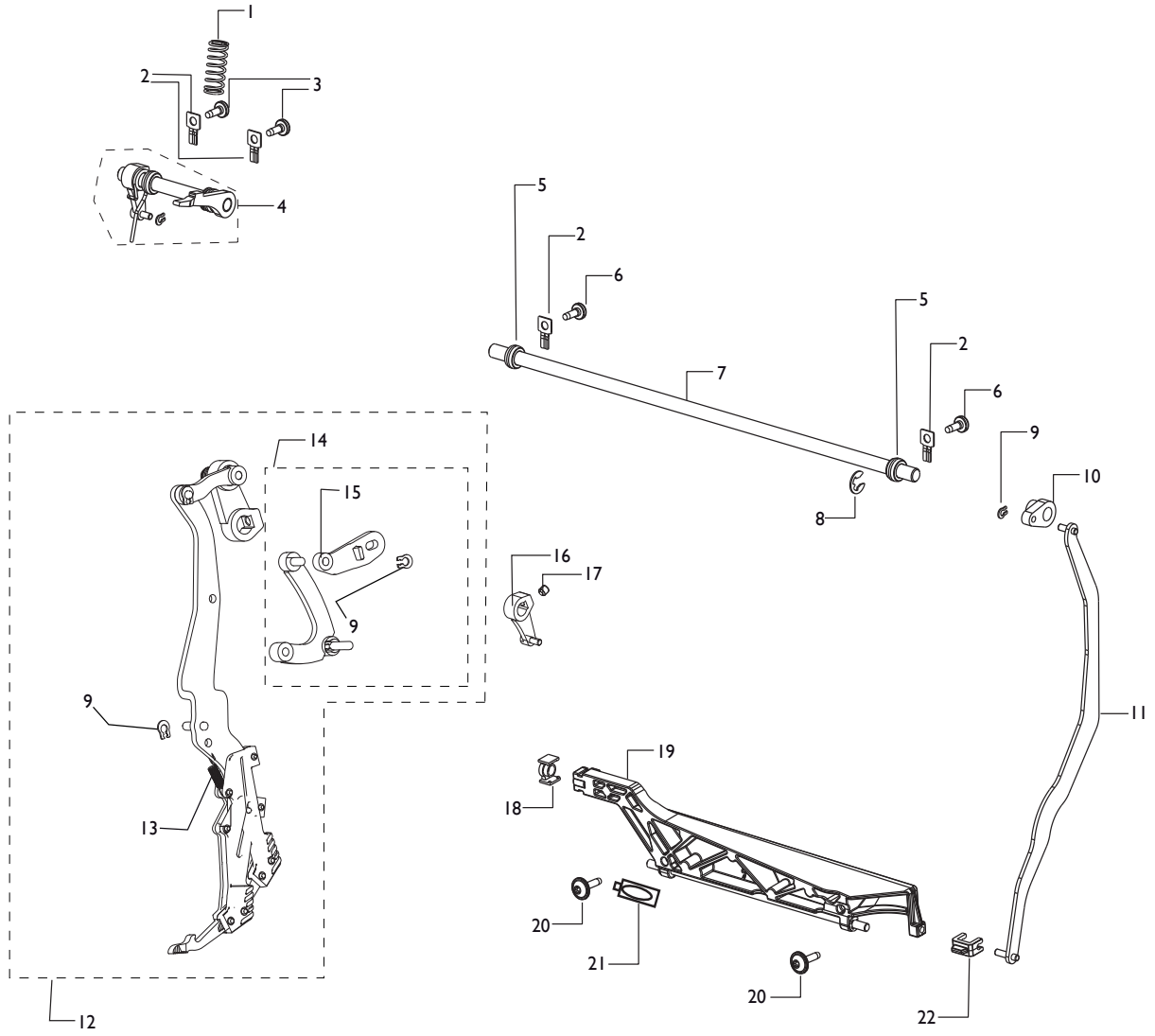

1	413065901	COMPRESSION SPRING, HEIGHT CAM
2	413042901	CLAMP, IDT
3	411966820	SCREW 30*10 FZB KOMBITORX
4	413065701	HEIGHT SHAFT, IDT CPL.
5	413042601	BEARING, IDT
6	412056005	SCREW TAPTITE M4*10 TORX
7	413042401	SHAFT UPPER, IDT
8	735310920	SNAP RING E-5
9	735612440	COMPRESSION RINGS Ø3
10	413042501	REAR CRANK, IDT
11	413043001	LINK IDT, LONG
12	413043202	ARM, IDT CPL.
13	413043101	COMPRESSION SPRING
14	413140802	TOGGLE LINK, IDT CPL.
15	413043601	LOWER SLEWING BACKET, IDT
16	413046201	HEIGHT CRANK, IDT CPL.
17	411968706	SET SCREW FLAT,M4*4 TORX
18	413042201	FEEDER BEARING, IDT
19	413041901	CONNECTOR FEEDER, IDT
20	413169401	COLLAR SCREW TT TORX 4*14
21	413140701	CLAMP SHAFT, IDT
22	413042001	CLAMPING, IDT

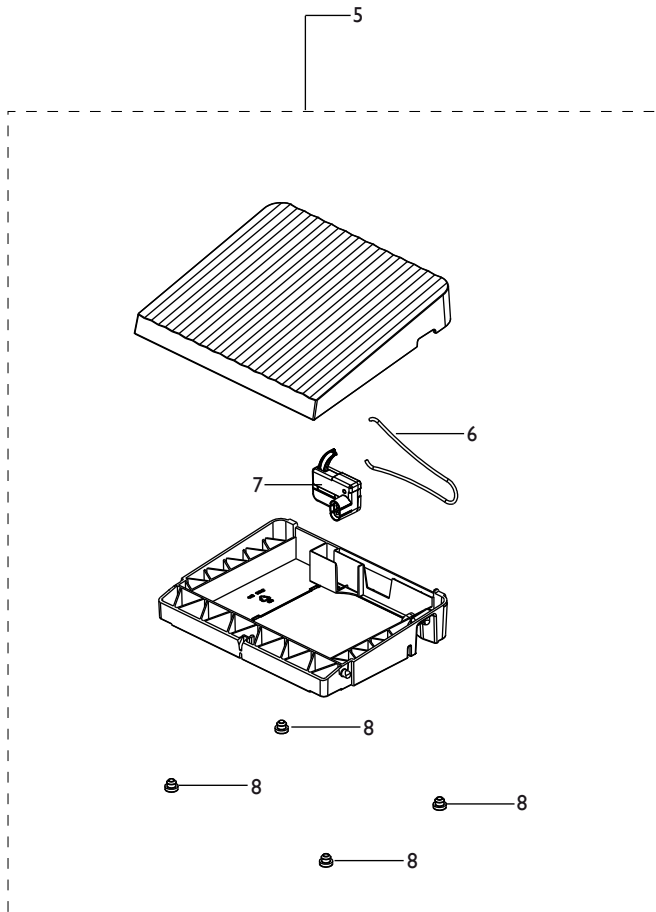
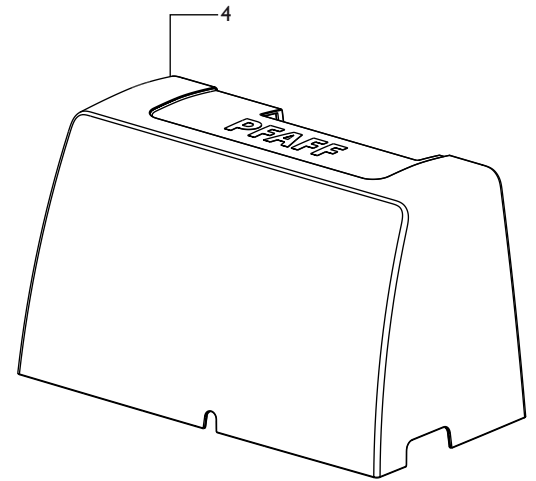
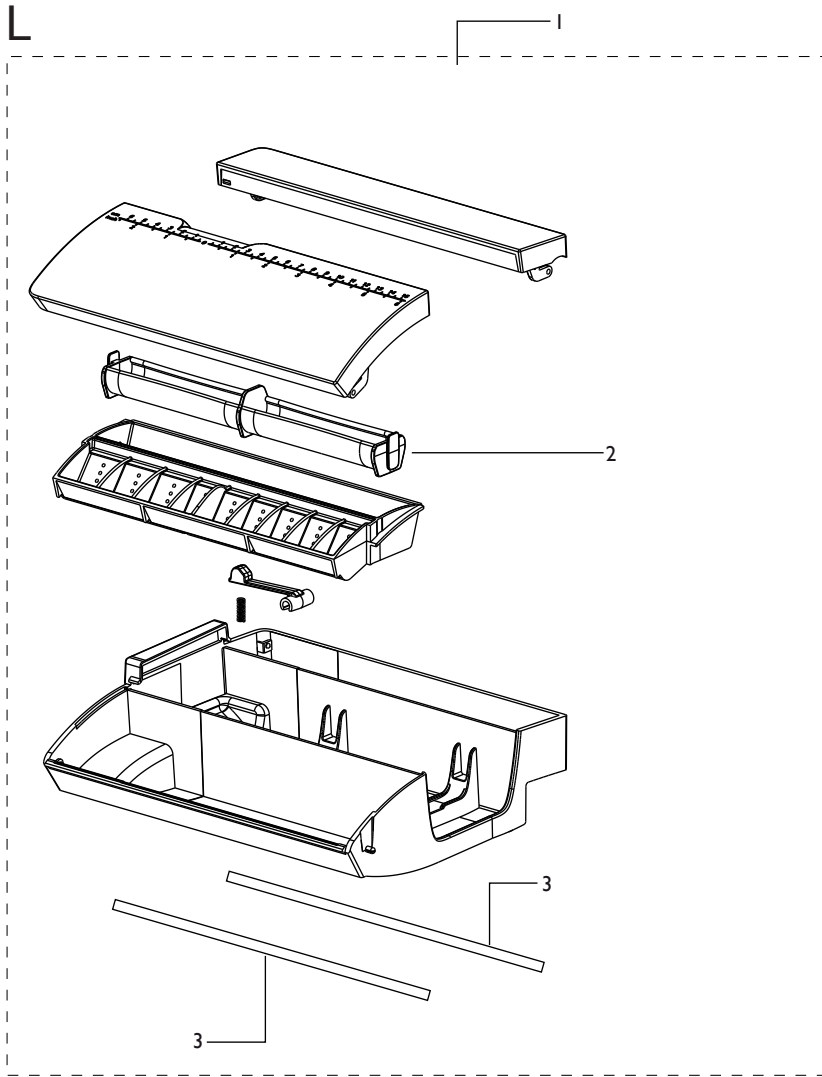

POWERCORD

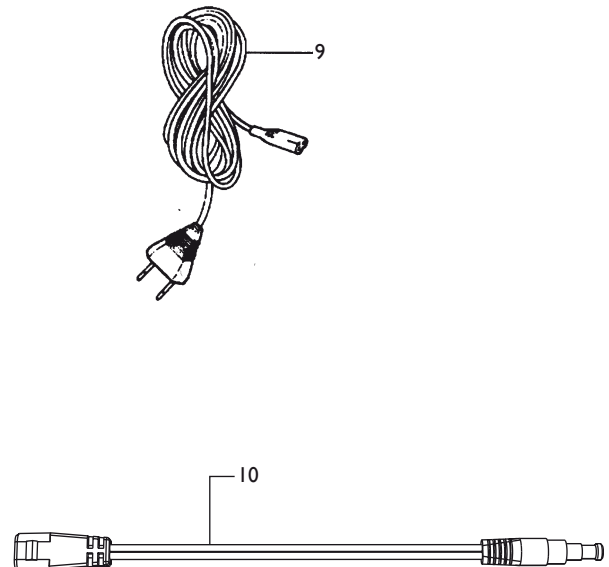

1	413083903	ACCESS.BOX CPL W. SPOOL HOLD.
2	412737401	BOBBIN HOLDER
3	412529702	FRICTION TAPE
4	413071903	COVER CPL.
5	412991401	FOOT CONTROL CPL. GREY N.WIND
6	412159801	SPRING
7	412318901	CONTROL UNIT INCL. CARD CV
8	412184501	FOOT
9	412157801	NET CABLE 220V
	412157903	NET CABLE 120V
	412158002	NET CABLE GB
	412158101	NET CABLE AU
10	413021501	CABLE, FOOT CONTROL

M

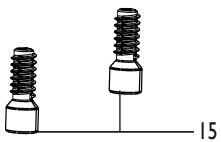
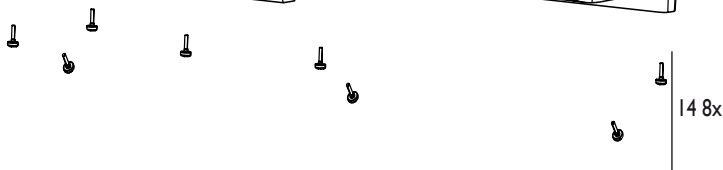
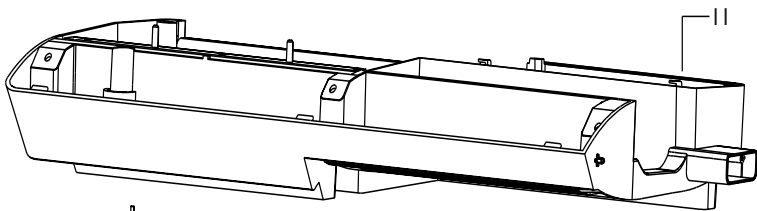
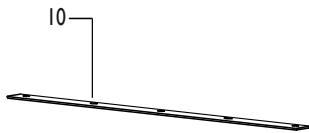
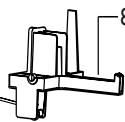
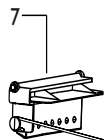
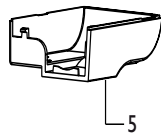
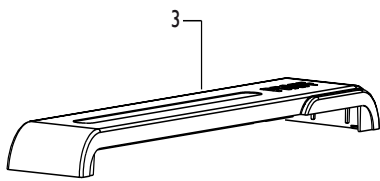
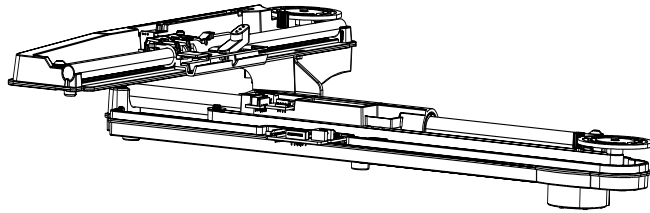
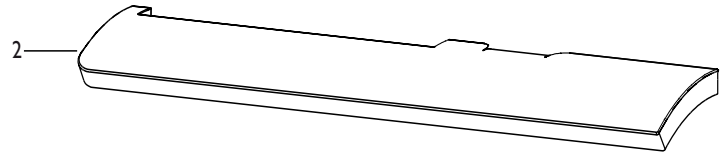
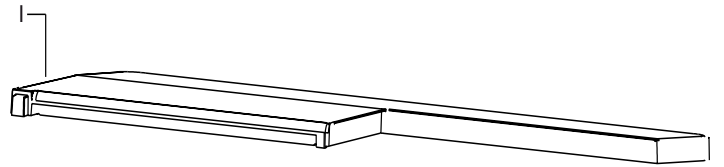

1	413126201	TOP COVER, XY-UNIT
2	413126301	COVER, XY-UNIT
3	413126501	COVER, Y-ARM, XY-UNIT
4	413027502	SUPPORT ARM, Y-ARM
5	413126601	MOTOR COVER, Y-ARM
6	412721401	SPRING, LATCH
7	413027701	HANDLE LATCH
8	413027601	LATCH
9	413027802	CONNECTING ROD, LATCH X=200
10	413126401	GUIDE SUPPORT ARM
11	413126101	BOTTOM COVER, XY-UNIT
12	413028801	CABLING, XY-UNIT CPL.
13	411966820	SCREW 30*10 FZB KOMBITORX
14	412056006	SCREW PT 40*10 FZB TORX
15	413028501	FOOT, XY-UNIT CPL.

N

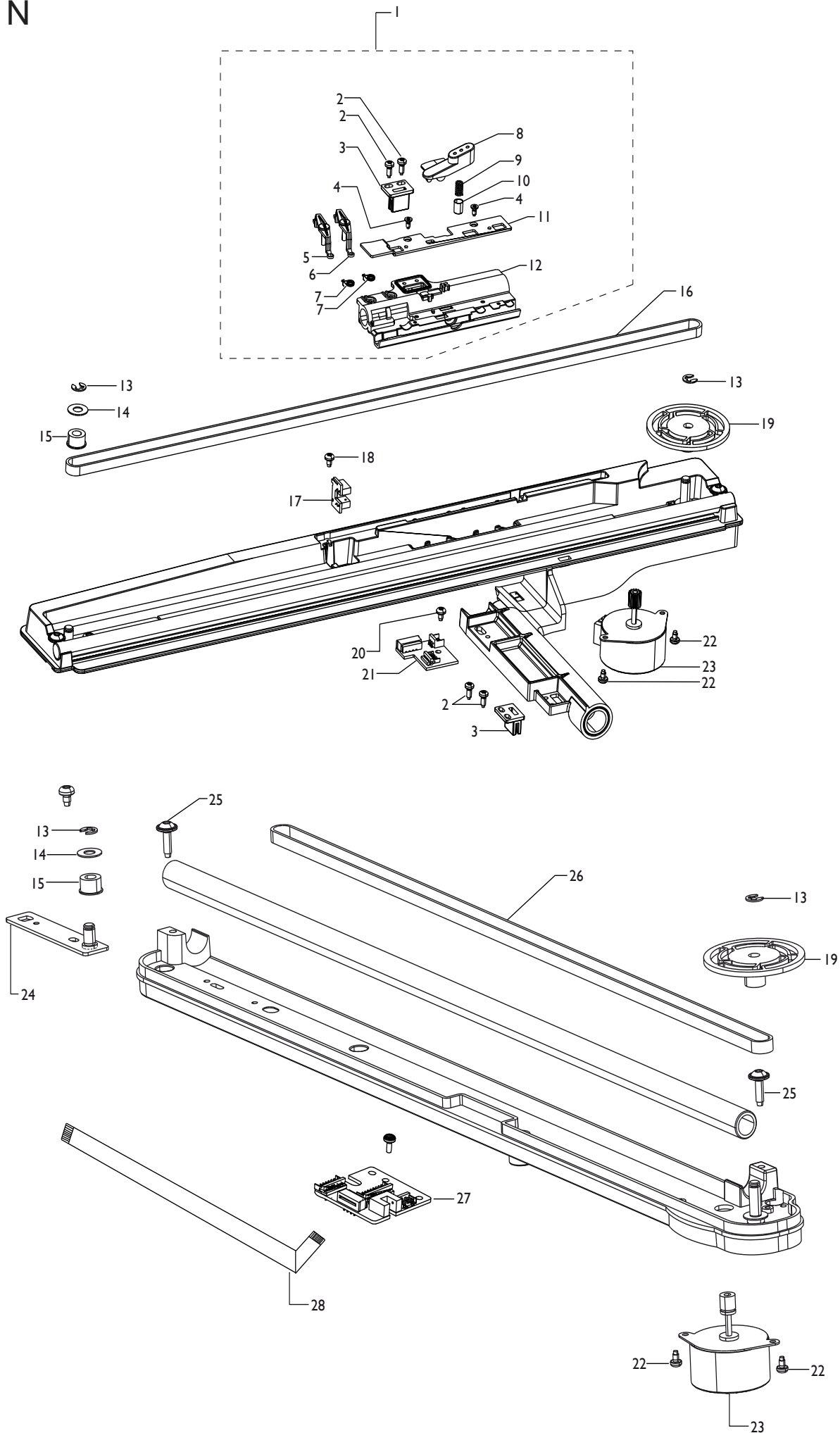

1	68006061	Y-SLED CPL.
2	411966801	SCREW PT 30*7,5 FZB TORX
3	412525301	HOLDER BELT
4	411967306	SCREW PT FS 25*6 OXSV TORX
5	68006008	HOOP INDICATOR BLACK
6	68006006	HOOP INDICATOR GREY
7	412555701	SPRING
8	413030201	LOCKING ARM Y-SLED
9	412526601	SPRING
10	412590003	SLEEVE
11	413026901	PANEL Y-SLED CPL.
12	413026801	Y-SLED
13	735310820	LOCK WASHER 4
14	412384301	WASHER 6/13*0,6
15	412384202	COG WHEEL
16	413075201	SYNCHRONOUS BELT, Y-FRAME
17	413029601	BOARD, HOOP DETECTION CPL.
18	412056011	SCREW TAPTITE M3*5 TORX
19	412524601	GEAR WHEEL
20	412056001	SCREW TAPTITE M5*14 TORX
21	413029301	BOARD, Y-ARM CPL.
22	412056004	SCREW TAPTITE M3*6 TORX
23	413029901	STEPPER MOTOR, XY-UNIT CPL.
24	412524901	PLATE BELT TENSION CPL.
25	412281904	SCREW FLANGE M4*10 TAPTITE TORX
26	412526702	Y-BELT
27	413029002	BOARD, XY-UNIT CPL. 260*200
28	412388107	FLEX CABLE



260x200

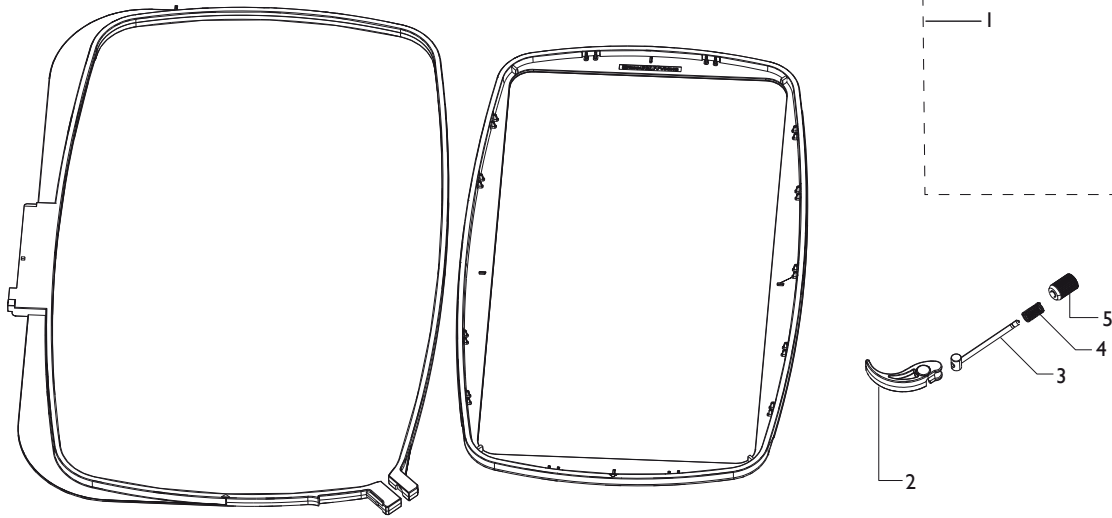

120x120

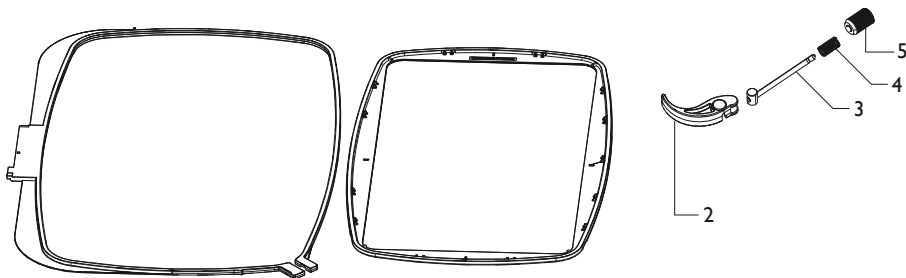

1	413116502	EMBROIDERY FRAME 260*200
2	412984701	LOCKING HANDLE EMBR.HOOP
3	412956204	SCREW CPL. HOOP
4	412620701	SPRING, EMBROIDERY HOOP
5	412996501	NUT, EMBR.FRAME
6	412968202	EMBROIDERY FRAME CPL. 120*115